

dspblok™ 21469

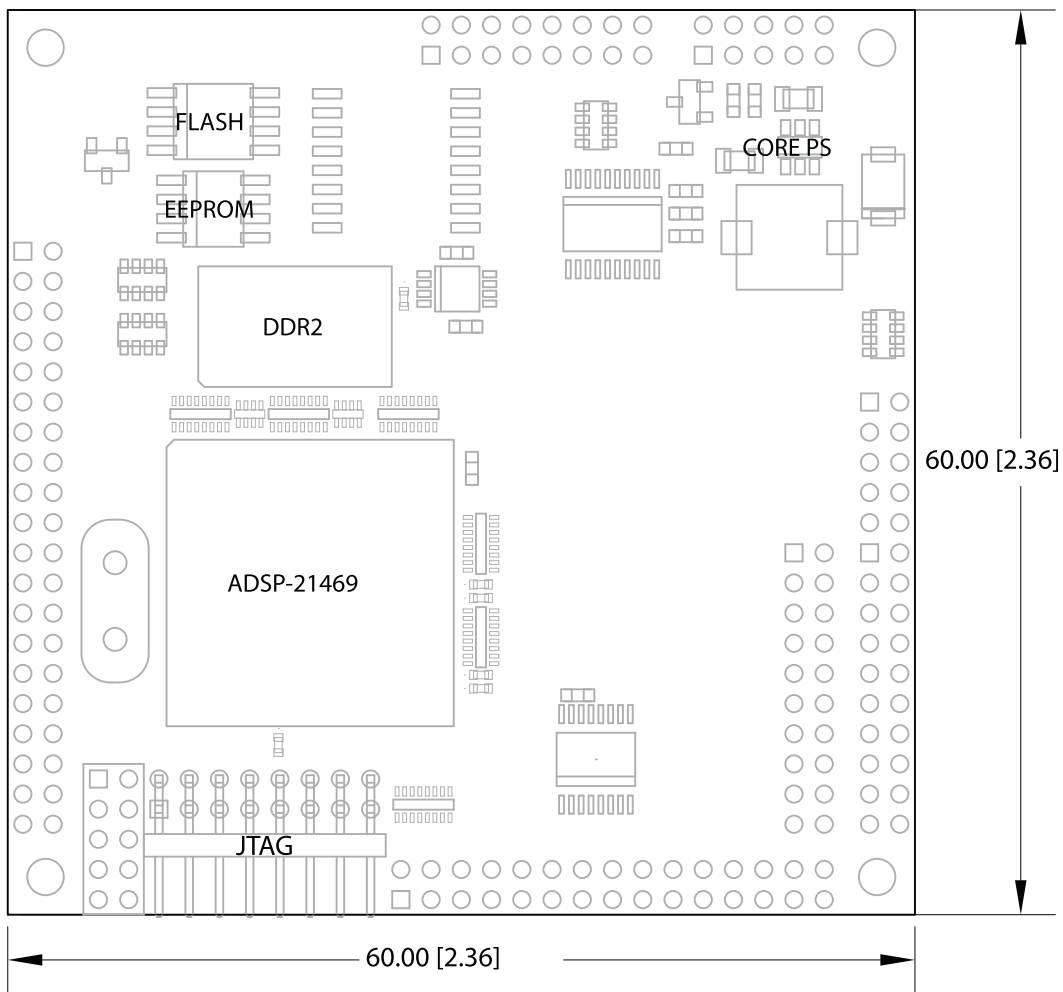

User Manual

Version 1.3

Danville Signal Processing, Inc.

dspblok™ 21469

User Manual

Copyright © 2009-2017 Danville Signal Processing, Inc. All rights reserved. Printed in the USA.

Under the copyright laws, this manual may not be reproduced in any form without prior written permission from Danville Signal Processing, Inc.

Danville Signal Processing, Inc. strives to deliver the best product to our customers. As part of this goal, we are constantly trying to improve our products. Danville Signal Processing, Inc., therefore, reserves the right to make changes to product specification or documentation without prior notice. Updated operating manuals and product specification sheets are available at our website for downloading.

This manual may contain errors, omissions or “typo’s”. Please send your comments, suggestions and corrections to:

Danville Signal Processing, Inc.
29687 82nd Avenue Way
Cannon Falls, MN 55009

Trademark Notice

dspblok, dspstak, dspFlash and dspBootloader are trademarks of Danville Signal Processing, Inc. VisualDSP++, CrossCore, SHARC and Blackfin are trademarks of Analog Devices, Inc.

Contact Information

Danville Signal Processing, Inc.
29687 82nd Avenue Way
Cannon Falls, MN 55009

E-mail: dsp@danvillesignal.com
Web Site: <http://www.danvillesignal.com>

Voice: 507-263-5854

Fax: 877-230-5629

Table of Contents

Overview.....	1
dspblok™ 21469.....	2
Intended Audience	2
Getting Started.....	2
Hardware Overview	5
Power Supply.....	5
Memory.....	7
DAI & DPI	7
Data Bus	7
Clocks.....	8
Link Ports.....	8
Multiprocessor Configurations.....	8
Reset.....	8
Signal Levels	8
Boot Options	8
Connections	9
Connector Recommendations & Notes	11
Connector Specification	11
JH1 – JTAG	11
JH2 – DAI, DPI, IO	11
JH3 – Configuration	11
JH4 – Power & Clock	11
JH5, JH7 – Data Bus	11
JH6 – Link Port	12
JH8 – dspBootloader Mode.....	12
Mechanical Dimensions (dspblok 21469).....	13
Schematic.....	14
Product Warranty	15
RoHS & WEEE Compliance.....	16

Overview

Danville Signal's dspblok™ family of products delivers the power of digital signal processing in a small 60mm x 60mm form factor. Connections are brought out to standard 2mm dual row headers. The dspblok reduces development costs, risk and time.

Danville's dspblok DSP function modules are often incorporated directly into larger custom embedded systems. By taking advantage of pretested signal processing modules, pc board layouts become simpler and projects are completed quickly and cost effectively. Danville's dspblok DSP Engines are largely pin compatible. This allows your application to take advantages of new processor technology and extended features in the future.

Each dspblok DSP module includes a core switching supply, flash and EEprom memory and the Danville dspBootloader application. Most dspblok DSP modules also include a USB transceiver. Some dspbloks also include external DDR SDRAM and/or external data busses.

There are two broad categories of dspbloks: standard and USB audio.

The standard dspbloks maximize the I/O that is available from the SHARC DSP. This translates to 12 of 14 DPI lines and all 20 DAI lines.

The USB Audio dspbloks have a companion processor that supports USB Audio Class 2 (UAC2). These are supplied with Windows device drivers and are supported natively by Apple OS X and Linux. Since the USB audio requires streaming and control connections, the amount of external I/O is restricted to a subset of the standard dspbloks.

You can learn more about these differences by reviewing the "dspblok Designing for Compatibility" manual.

Danville dspblok DSP Engines are the driving force behind many of Danville's standalone products such as our dspstak™, dspMusik™ and dspInstrument™ product lines.

dspblok™ 21469

The dspblok™ 21469 is a highly integrated DSP module that incorporates an Analog Devices' ADSP-21469 SHARC DSP operating at 450 MHz with flash, EEPROM and DDR2 SDRAM memory. An onboard switching power supply supports the core voltage requirements of the DSP so that only 3.3V is required to power the dspblok. The ADSP-21469 peripherals include SPORTS (8), SPI(2), TWI (I2C), UART, timers, PWMs, JTAG, an 8 bit wide data bus and LINK ports(2). All of these peripherals are available via 2mm headers on the dspblok.

Intended Audience

The dspblok 21469 requires an understanding of the Analog Devices' ADSP-21469 and the associated tools used for development. If the dspblok 21469 is going to be integrated into a larger hardware design, then it is also assumed that the user is familiar with basic hardware design. In most cases, systems integrators, DSP programmers and software engineers can create DSP embedded systems using our embedded dspblok systems (or dspstak family) without the need for additional hardware design and manufacturing.

If you do not have a background with these skills, you may want to check out our web site (<http://www.danvillesignal.com>) as well as the Analog Devices web site for links to useful references. Danville engineers are also available to discuss your application.

Getting Started

Danville's customer base is quite diverse. Our customers range from embedded systems hardware designers to system integrators looking for complete turnkey solutions. We often work with embedded systems engineers who may not have specific expertise in digital signal processing.

Regardless of your background, you will need the right tools. This means either Visual DSP++ 5.1.1 for SHARC or CrossCore Embedded Studio for the software development along an ADI emulator.

Visual DSP++ 5.1.1 versus CrossCore Embedded Studio:

VisualDSP++ has been ADI's DSP software environment for many years. In many ways, it has a similar look and feel to Microsoft's Visual Studio Tools. There are separate licenses for SHARC and Blackfin so customers that need to support both families often need to buy two full licenses. In our view, the full version of VisualDSP++ is expensive, about \$3500 US. However, once you own VisualDSP++, you can continue updating for free. Version 1.0 customers can now be using Version 5.0 without incurring any maintenance charges. There are also KIT and TESTDRIVE licenses, which are free.

CrossCore Embedded Studio is ADI's replacement for VisualDSP++. Unlike VDSP++, it is Eclipse based. It has a much lower entry cost: \$1000 US. It will likely have upgrade costs as new processors are added. This may not matter at all if you are not migrating to newer DSPs. CrossCore supports both Blackfin and SHARC DSP with a single license. ADI offers a free 90 day TESTDRIVE version.

dspblok 21469 with an ADI ICE :

Start your development with a dspblok 21479 module. In this case, you will want to connect to the dspblok 21469 via an external Analog Devices emulator. Analog Devices offers two versions: the ICE-1000 and the ICE-2000. We prefer the faster ICE-2000, which is nearly 10 times faster and also supports background telemetry. You will also need a Danville JTAG adapter kit (P/N A.08153), which converts the Danville JTAG 2mm header to the larger ADI JTAG connector.

You will also need a FULL VisualDSP++ 5.1.1 or CrossCore Embedded Studio license after 90 days.

Development Boards:

If you are designing your own companion board, we strongly recommend that you use one of our existing I/O boards and/or power supply boards as an initial development platform. Depending on your situation, this could be a dspblok dev board, dspstak system, dspInstrument, or a combination of dspblok I/O and power supply modules. Any of these components will give you a solid footing for development before you incorporate the dspblok into your own target.

If you are laying out your own pc board, we can provide you with PCB footprints and schematic symbols (Gerber & Altium Designer) to help you avoid simple mistakes.

Regardless of your situation, Danville engineers are available to help you with your application. We may have solutions that are not yet on our web site. We also provide many solutions that are specifically tailored to customer needs. Contact us about turnkey solutions.

We recommend that you have the documents:

- Danville Signal Designing for Compatibility Manual
- Danville Signal dspBootloader Manual
- Analog Devices ADSP-21467/ADSP-21469 SHARC Processor Data Sheet
- Analog Devices ADSP-214xx SHARC Processor Hardware Reference Manual
- Analog Devices SHARC Processor Programming Reference Manual
- Analog Devices VisualDSP++ 5.0 Manual Set

We recommend that you have the tools:

- Analog Devices VisualDSP++ 5.1.1 for SHARC or CrossCore Embedded Studio
- Analog Devices ICE-1000 or ICE-2000
- Danville JTAG Adapter P/N A.08153
- Danville dspblok Development Board P/N A.08102A

Our website (www.danvillesignal.com) has downloads and links to these tools and documents.

The dspblok 21469 includes the following:

Hardware:

- dspblok 21469 Module

Documents (Dropbox link or DVD)

- This Manual
- CAD footprints (Gerber & Altium formats)
- Schematics
- Sample Programs

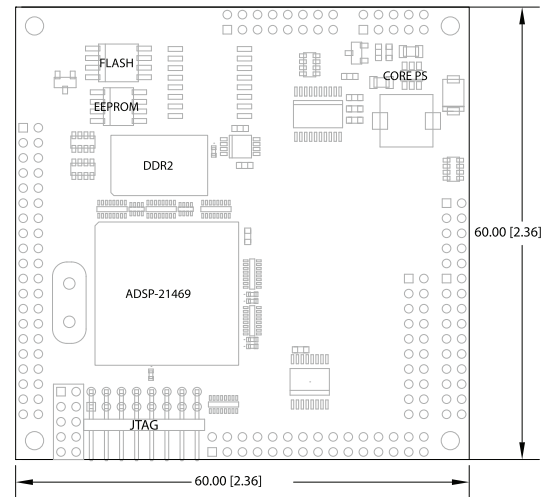

Hardware Overview

The dspblok 21469 is a small module measuring 60mm x 60mm (2.36" x 2.36"). JH2 and JH4 – JH8 are 2mm male headers that are installed on the bottom side of the pc assembly. JH1 and JH3 are mounted on the top side of the pc assembly. If mating 2mm female headers (4.3mm ht.) are used, the pc assembly will be about 1/4" above the mating pc board. This allows standard (0.250") standoffs to be used with the corner mounting holes if desired. The hole size is 2.3mm – suitable for 2-56 or M2 screws.

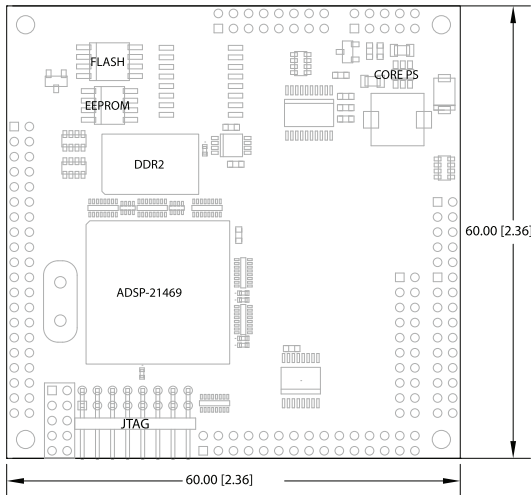

- JH1 – JTAG (connects to external ICE)
- JH2 – DAI, DPI, I/O, SPI & System
- JH3 – Clock & Boot Configuration)
- JH4 – Power & Ext Clock
- JH5, JH7 – Data Bus
- JH6 – Link Ports
- JH8 – dspBootloader Mode

Power Supply

There are two power supply connections to the dspblok: DSP core (Vdd) and DSP I/O and Memory (Vd+3.3). The DSP core supply may range from 3.3V to 5V. This is the input to an on-board switching power supply that supplies 1.1V to the ADSP-21469. DO NOT use a higher voltage supply for the core supply input (JH4-Vdd).

A single 3.3V supply is all that is required to power the dspblok 21469, but in some cases, a 5V supply may be more convenient. The DSP I/O and Memory supply must be 3.3V.

For example, a product may already have a switching supply that converts directly to 3.3V. In this case, it may be desirable to supply both the DSP core and the dspblok Vd+3.3 (I/O) from this supply.

Alternatively, a product might have a 5V supply (perhaps from an external power supply module). A simple LDO fixed regulator could be used to create 3.3V from this supply. Most high-speed devices, including the ADSP-21469, draw most of their power from their core supplies. In this scenario, it makes no sense to power the dspblok core with 3.3V since the LDO would be dissipating the excess voltage as heat. If the I/O requirements are modest, the power dissipation in the LDO might not be significant

Power consumption is largely a function of the temperature of (leakage current) of the ADSP-21469. It is also a function of the core clock and the computation tasks that are being executed on the DSP. The highest consumption occurs when the DSP is performing continuous floating point operations at maximum core clock (450MHz) and at maximum temperature. Accessing external I/O such as the DRAM or other peripherals consumes less power in the benchmarks that we have performed. The following table shows power consumption measurements for a typical dspblok 21469 operating in a variety of configurations all at

room temperature. The Analog Devices' ADSP-21467/ADSP-21469 SHARC Processor Data Sheet has an excellent section on estimating power consumption of the DSP. Please note that the measurements do not take into account the increase static current as temperature rises.

Typical Power Consumption at Room Temperature

Core Clock	Continuous floating point operations	Mixed floating point & DAI operations	Mixed floating point & DDR2 operations	Continuous floating point operations	Mixed floating point & DAI operations	Mixed floating point & DDR2 operations
Vdd = 3.3V & Vd+3.3						
	mA	mA	mA	mW	mW	mW
100MHz	145mA	143mA	143mA	479mW	472mW	472mW
200MHz	150mA	148mA	147mA	568mW	554mW	554mW
400MHz	214mA	209mA	208mA	769mW	746mW	746mW
450MHz	231mA	225mA	225mA	822mW	795mW	795mW
Vdd = 5.0V						
	mA	mA	mA	mW	mW	mW
Vdd = 5V Core Supply Only						
100MHz	84mA	84mA	84mA	280mW	275mW	275mW
200MHz	101mA	108mA	101mA	365mW	355mW	355mW
400MHz	164mA	168mA	162mA	525mW	510mW	510mW
450MHz	178mA	173mA	174mA	565mW	545mW	545mW
Vd+3.3 Supply Only						
100MHz	48mA	48mA	48mA	168mW	172mW	168mW
200MHz	54mA	54mA	54mA	185mW	185mW	185mW
400MHz	65mA	64mA	68mA	215mW	215mW	218mW
450MHz	67mA	67mA	67mA	224mW	224mW	224mW
Composite Vdd & Vd+3.3						
100MHz				448mW	447mW	443mW
200MHz				550mW	540mW	537mW
400MHz				740mW	725mW	728mW
450MHz				789mW	769mW	769mW

Memory

The ADSP-21469 includes an on board DDR2 DRAM controller. Unlike earlier SHARC processors, the DRAM interface is largely independent of the external data bus. On the dspblok 21469, the only overlap is MS0#, which is not available because its address is assigned to DDR2_CS#.

The dspblok 21469 uses a 1Gb (64M x 16) DDR2 DRAM. DDR2 memory is much faster and typically much larger than older SDRAM. PC board layout is non trivial. The dedicated DDR2 interface of the ADSP-21469 has been carefully laid out with respect to trace length, signal integrity, and bus isolation so that the DDR2 operates reliably at maximum speed. The CD includes examples of DDR2 register configuration code.

A 16Mbit serial flash memory may be used to bootstrap the DSP. There is a pre-installed bootloader program that resides in the flash. This program accepts standard ADI loader files (SPI, slave, binary, 8 bit) and can be uploaded with a Danville dspblok development board, a dspstak 21469 or any board that includes a USB connector to JH8. If you want to manage the flash memory yourself, you can overwrite the internal bootloader via the JTAG port. In this case, the Danville dspFlash™ Blackfin & SHARC Programmer is available for fast production programming.

64kbits of EEPROM memory is also available as byte addressable user memory. For example, you might store serial numbers, build versions or calibration values in this space.

There are other Flash/EEPROM combinations available via special order. Contact Danville if you have special memory requirement needs.

DAI & DPI

The ADSP-21469 has 20 DAI lines and 14 DPI lines. Collectively these can be thought of as two sets of crossbar switches that connect to a wealth of peripherals. The dspblok 21469 maintains the flexibility of the DAI and DPI by bringing out all 20 DAI and 12 of 14 DPI lines to external connections.

The DAI is completely unencumbered and can be assigned to I/O in an arbitrary manner. The DPI is slightly restricted in that the primary SPI interface is assigned to DPI1 (MOSI), DPI2 (MISO), DPI3 (SCK), DPI5 (Flash SS) and DPI6 (EE SS). With the exception of DPI6, these connections are necessary to support SPI master booting. The dspblok 21469 may also be booted from an external host using SPI slave mode. In this case DPI4 is also used as the SPIDS# line.

Data Bus

The dspblok 21469 brings out the complete asynchronous data bus including all address lines with the exception of MS0# which would be in conflict with the DDR2 chip select.

The upper portion of MS1# is used for on-board peripherals. The lower $\frac{3}{4}$ of the address space is available. MS2# and MS3# can also be used as FLAG2 and FLAG3, respectively. They are configured together so MS1# might be used for the external data bus and FLAG2 & FLAG3 for other purposes.

Clocks

The dspblok 21469 supports both internal and external clocking options. You can add a standard HC49 style crystal to the board for internal clocking or you can supply an external clock. The configuration header (JH3) allows any ADSP-21469 power-up clock configuration to be set.

Link Ports

The dspblok 21469 has two link ports available that can be used to interface to additional dspblok 21469 boards or may be used to connect to other external devices such as FPGAs.

Multiprocessor Configurations

The dspblok 21469 may be used as a coprocessor in a larger system. Perhaps the easiest way to communicate with an external host to configure the secondary SPI port as a slave. The primary SPI port remains configured as an SPI master so that it can manage local resources such as flash and EE memory as well as other I/O devices.

Certainly, the Link Ports are available for multiprocessor systems. They are ideal where fast interprocessor communications are required. Since clocks and data are always driven from the same source, clock skew is minimized.

You can also use SPORTs for interprocessor communication. This can be a good approach for Blackfin – SHARC combinations. It also works well for multichannel applications where you might use several dspbloks to provide front end signal processing and combine into a consolidated TDM data stream. The results could be routed to a central processor that manages the whole system and communicates to the outside world.

Reset

On power up, the dspblok 21469 is automatically held in reset until the 3.3V power supply is stable. RESET# is active low and open drain. This means that an external device(s) may also reset the dspblok by pulling the reset line low. External devices should not drive RESET# high since this can cause contention with the on-board reset circuit. The external reset circuit is connected in a wired-OR configuration using an active low – open drain configuration. A 74LVC125 or an open collector/drain transistor circuit are possibilities. You do not need an additional pull up resistor.

Signal Levels

The dspblok 21469 uses standard 3.3V logic levels. These levels have become the defacto operating standard for many years now. DO NOT use 5V logic when interfacing to the dspblok. The inputs are not 5V tolerant. Most external devices requiring 5V TTL levels can be safely driven by the dspblok. If you have questions concerning interfacing external devices, please contact Danville for suggestions.

Boot Options

All ADSP-21469 boot options are available via the configuration and programming header (JH3). These include Master SPI (flash memory), Slave SPI (external host) or Link Port. The boot mode pins are pulled passively to create a default boot mode of SPI Master.

Connections

	Pin	Description		Pin	Description		Pin	Description
JH1		JTAG		JH2	DAI, DPI, IO		JH3	Configuration
	1	EMUSEL		1	GND		1	GND
	2	EMU		2	DPI8/IO0/SS1#	Note 4	2	BOOTCFG0
Note 1	3	Key (No Pin)	Note 2	3	DPI4/IO1/SS2#		3	Vd+3.3
	4	GND		4	DPI13/IO2/SS3#	Note 4	4	BOOTCFG1
	5	Vd+3.3 Mon		5	DPI14/IO3/SS4#		5	Vd+3.3
	6	TMS		6	FLG0/IO4/SS5#	Note 4	6	BOOTCFG2
	7	GND		7	DPI7/SS0#		7	Vd+3.3
	8	TCK		8	DPI11/I2C_SDA	Note 5	8	CLKCFG0
	9	GND		9	DPI12/I2C_SCL		9	GND
	10	TRST#		10	DPI9/UART_TX	Note 5	10	CLKCFG1
	11	GND		11	DPI10/UART_RX			
	12	TDI		12	FLG1		JH4	Power
	13	GND	Note 3	13	Reserved			
	14	TDO		14	DPI1/MOSI		1	GND
	15	Vd+3.3		15	DPI3/SCK		2	Ext Clk
	16	Vd+3.3		16	DPI2/MISO	Note 6	3	Vd+1.1
				17	RESET#		4	DSP ClkOut
JH8		dspBootloader	Note 3	18	Reserved		5	Vd+3.3
				19	DAI1		6	Vd+3.3
	1	NC		20	DAI2	Note 7	7	Vdd (3.3V or 5V)
	2	NC		21	DAI3	Note 7	8	Vdd (3.3V or 5V)
	3	Reserved		22	DAI4	Note 8	9	PS Sync
	4	NC		23	DAI5		10	GND
	5	GND		24	DAI6			
	6	GND		25	DAI7			
	7	Reserved		26	DAI8			
	8	Reserved		27	DAI9			
	9	GND		28	DAI10			
	10	GND		29	DAI11			
	11	Reserved		30	DAI12			
	12	GND		31	DAI13			
	13	USER MODE 1		32	DAI14			
	14	GND		33	DAI15			
	15	USER MODE 0		34	DAI16			
	16	GND		35	DAI17			
				36	DAI18			
				37	DAI19			
				38	DAI20			
				39	GND			

				40	GND			
	Pin	Description		Pin	Description		Pin	Description
JH5		Data Bus	JH7		Address Bus	JH6		Link Port
Note 9	1	NC	Note 9	1	NC		1	L0DAT0
Note 9	2	NC	Note 9	2	NC		2	L0DAT1
Note 9	3	NC	Note 9	3	NC		3	L0DAT2
Note 9	4	NC		4	A23		4	L0DAT3
Note 9	5	NC		5	A22		5	L0DAT4
Note 9	6	NC		6	A21		6	L0DAT5
Note 9	7	NC		7	A20		7	L0DAT6
Note 9	8	NC		8	A19		8	L0DAT7
Note 9	9	D7		9	A18		9	LCLK0
	10	D6		10	A17		10	LACK0
	11	D5		11	A16		11	L1DAT0
	12	D4		12	A15		12	L1DAT1
	13	D3		13	A14		13	L1DAT2
	14	D2		14	A13		14	L1DAT3
	15	D1		15	A12		15	L1DAT4
	16	D0		16	A11		16	L1DAT5
	17	RD#		17	A10		17	L1DAT6
	18	WR#		18	A9		18	L1DAT7
	19	ACK		19	A8		19	LCLK1
Note 8	20	NC		20	A7		20	LACK1
				21	A6			
				22	A5			
				23	A4			
				24	A3			
				25	A2			
				26	A1			
				27	A0			
				28	MS1#			
				29	MS2#			
				30	MS3#			

Note 1: Mating Plug is plugged to prevent misalignment.

Note 2: DPI4 also functions as SPIDS# in SPI slave booting applications.

Note 3: Leave Unconnected.

Note 4: Boot Configuration is 001 by default (SPI Master Booting).

Note 5: Clock Configuration is 10 by default (16 x ClkIn), generally reconfigured in program code.

Note 6: Vd+1.1 is for power supply monitor only (DSP Core supply).

Note 7: Vdd is externally supplied: 3.3 to 5V (Vin for DSP Core Switching supply). Both connections must be the same voltage.

Note 8: Leave open or supply 1.4 to 1.6M clock, typically data converter MCLK/N

Note 9: Not Connected, may be used for extended features by other dspbloks.

Connector Recommendations & Notes

Connector Specification

All dspblok connectors are gold plated 2mm dual row headers. Male connectors are generally mounted on the bottom side of the dspblok pc assembly. The exceptions are JH3 & JH1, which are not intended to mate to a motherboard. Mating female connectors are included for your target pc board. The plastic base of each male connector is 2mm. The height of the female headers is 4.3mm. This means that the inserted combined height of the two connectors is 6.3mm or approximately ¼ inch. Standard standoffs may be used to secure the dspblok to the target pc board. Mounting holes are 2.3mm dia. to accommodate a 2-56 or M2 screws or standoffs.

JH1 – JTAG

This connector is mounted on the top side of the dspblok. A 2mm right angle header is used instead of the larger ADI JTAG header. The connections on the JTAG header correspond with the connections on an ADI JTAG header. In addition, Vd+3.3 is also available. This addition allows an active buffer circuit to be added for JTAG chaining applications. Danville has an ADI JTAG adapter available (P/N A.08153).

JH2 – DAI, DPI, IO

This connector is mounted on the bottom side of the dspblok. The DAI lines are all uncommitted by the dspblok. With the exception of the SPI lines, the DPI can be freely assigned. The alternate names in the table are dspstak I/O conventions. If you are using a dspstak for development, it may be prudent to following these usage conventions.

JH3 – Configuration

This connector is mounted on the top side of the dspblok. It provides direct access to the ADSP-21469 clock mode and boot mode configuration pins. In most cases, you should leave all the connections open. Use shorting jumpers if you want to change the configuration. Note that each shorting jumper will cause the corresponding mode pin to deviate from the pin state of the default configuration. This means that some pins are pulled high and others low.

JH4 – Power & Clock

This connector is mounted on the bottom side of the dspblok. This is the main power feed to the dspblok, Vdd is the input to the core switching supply. Both Vdd pins should be connected to together and fed with either 5V or 3.3V. Likewise, Vd+3.3 should be connected together and fed with 3.3V. Vd+1.1 is current limited by a large resistor. Its purpose is for diagnostics.

JH5, JH7 – Data Bus

The data bus is split to two separate connectors, one for address and the other for data. The ADSP-21469 has an 8 bit data bus. Earlier dspbloks based on the ADSP-21369 supported a 32 bit data bus. This was needed primarily to support wide SDRAM interfacing. The original JH6 connection on the dspblok 21369zx

board was used for the extended data bus. This is also why there are unused pins on JH5. If you are adapting a dspblok 21369zx design to support the dspblok 21469, you should verify that these changes will not impact your design. In most cases, this will not be an issue.

The address bus is also organized so that the MS# lines and the lower address lines are grouped together. This allows a smaller receptacle to be used when the whole address space is not required.

JH6 – Link Port

The Link Port connections include 33 ohm series terminators as well as 10K pulldowns for LCLKx and LACKx. The series terminators will have minimal effect when located on the receive side of a link port connection, but are required on the driving end of a link port connection.

If you are connecting another non-dspblok device to a link port, make sure your circuit includes series terminators at the driving end of any connection. These terminators are often available internally in FPGAs. You should not supply additional terminators on the dspblok side of a connection.

Link ports circuits are fast so careful attention to pcb layout and/or cabling is essential. Consult a Danville engineer if you have questions about this topic.

JH8 – dspBootloader Mode

JH8 supports the Danville dspBootloader. The dspBootloader allows you to upload your application and any supporting files via a variety of different ports. If the connections are left open, the dspBootloader will operate in its default setting. We recommend that you bring the mode pins out to an external configuration header or a dip switch.

You should review the dspBootloader manual for detailed information.

Mechanical Dimensions (dspblok 21469)

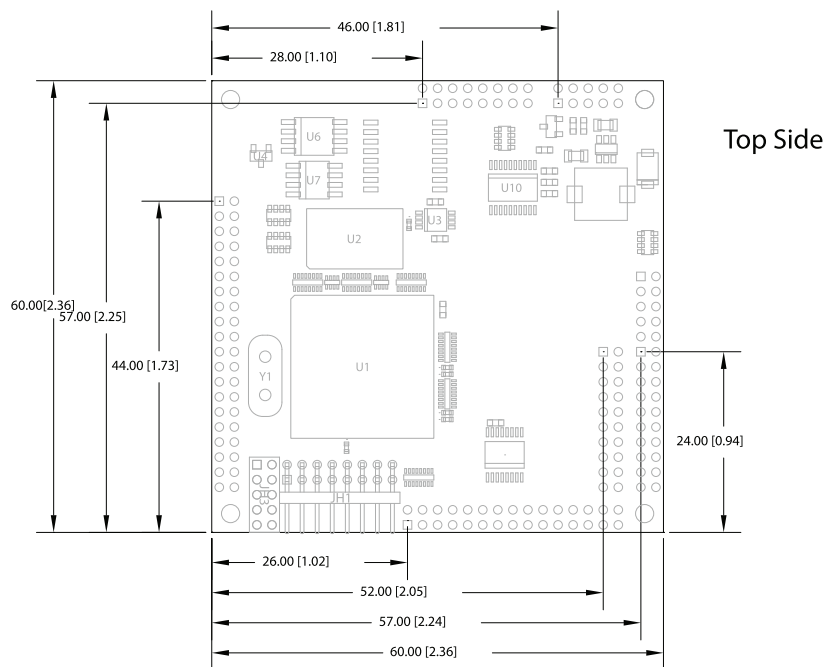

Holes 2.3 [0.090] (4 places)

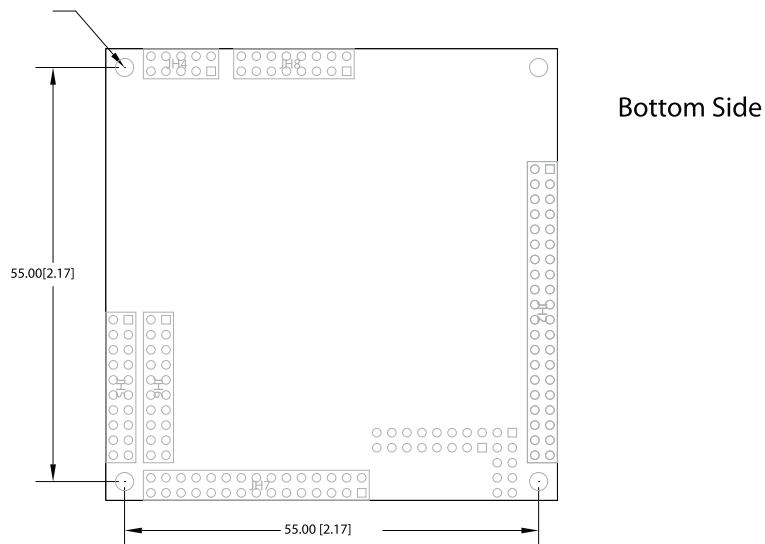

Mounting holes are equidistant from the center of the dspblok. These holes are 2.3mm in diameter, suitable for 2-56 or M2 screws. When 4.3mm height mating female connectors are used, the board will be 6.3mm (0.25 in) above the target board, therefore 0.250 standoffs may be used.

Component height above the board is 6mm (0.236 in). The board is 1.6mm (0.062 in) thick.

Schematic

The Distribution DVD or Dropbox link includes schematic diagrams of the dspblok 21469.

Product Warranty

Danville Signal Processing, Inc. products carry the following warranty:

Danville Signal Processing products are warranted against defects in materials and workmanship. If Danville Signal Processing receives notice of such defects during the warranty period, Danville Signal Processing shall, at its option, either repair or replace hardware products, which prove to be defective.

Danville Signal Processing software and firmware products, which are designated by Danville Signal Processing for use with our hardware products, are warranted not to fail to execute their programming instructions due to defects in materials and workmanship. If Danville Signal Processing receives notice of such defects during the warranty period, Danville Signal Processing shall, at its option, either repair or replace software media or firmware, which do not execute their programming instructions due to such defects. Danville Signal Processing does not warrant that operation of the software, firmware, or hardware shall be uninterrupted or error free.

The warranty period for each product is one year from date of installation.

Limitation of Warranty:

The forgoing warranty shall not apply to defects resulting from:

- Improper or inadequate maintenance by the Buyer;
- Buyer-supplied software or interfacing;
- Unauthorized modification or misuse;
- Operation outside the environmental specification of the product;
- Improper site preparation and maintenance.

Exclusive Remedies:

The remedies provided herein are the Buyer's sole and exclusive remedies. In no event shall Danville Signal Processing, Inc. be liable for direct, indirect, special, incidental or consequential damages (including loss of profits) whether based on contract, tort, or any other legal theory.

RoHS & WEEE Compliance

The European Union approved a directive on the restriction of the use of certain hazardous substances in electrical and electronic equipment. This directive is commonly known as RoHS, EU Directive 2002/95/EC. This directive severely limits the amount of lead and 5 other substances that can be in contained in nonexempt products. The directive became European law in February 2003 and took effect July 1, 2006.

It is likely that other countries outside the European Union and some states in the United States may adopt similar legislation.

There are a number of important exemptions that affect many of our customers. The most important of these is Category 9, Control and Monitoring Instruments. You may wish to review your situation to see if this exemption applies to you. Military, medical and some other products are also exempt. We suggest that you make an appropriate assessment concerning your products.

The dspblok 21469 is RoHS compliant.

The dspblok 21469 is a subcomponent of a larger system; therefore it is not subject to the WEEE directive EU Directive 2002/96/EC.